

# SPECIFICATIONS

MODEL | AC-CBK322  
MATERIAL | 2000D CANVAS  
INNER MATERIAL | MYLAR

PLATE | STEEL  
FRAME | 22mm STEEL  
SHELF WEIGHT CAP. | 10 lbs

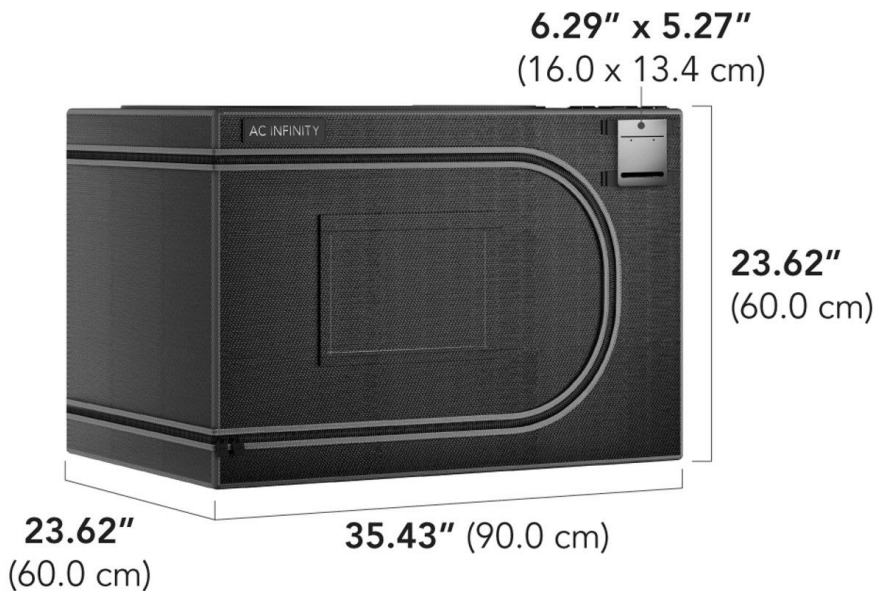

## MULTIPURPOSE BARS

(x2) **33.58"** (85.3 cm)



## SHELF RACKS (x2)

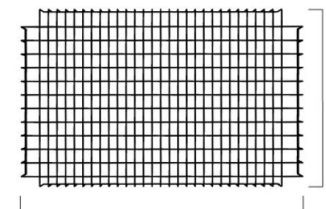

### FAN RECOMMENDATION

4" Inline Fan

### PLANT CAPACITY

5 Humidity Domes/1 Plant

### VIEWING WINDOW

(x2) 7.48" x 11.02" (19.0 x 28.0 cm)

### DIMENSIONS

24" x 24" x 36" = 12 ft<sup>3</sup>

### DUCT OPENINGS

(x3) 3.97" Ducting Ports

### MESH VENTS

(x2) 9.86" x 5.13" (25.0 x 13.0 cm)

# SPECIFICATIONS

UIS™

MODEL | CLOUDFORGE T3 (AC-CFT3)  
CAPACITY | 4.5 L (1.15 gal)  
ENGINE | Ultrasonic Vaporizer

OUTPUT RATE | 240 ml/h  
MAX RUNTIME | 45 hours  
WATTAGE | 24 Watts



6.77"  
(17.2 cm)

Flexible Hose Length:

28.74"      82.67"  
(73.0 cm) to (210.0 cm)



14.05"  
(35.7 cm)

6.77" (17.2 cm)



Sensor  
Probe  
Length:

144"  
(366.0 cm)



Power  
Cord  
Length:

95.27"  
(242.0 cm)

# SPECIFICATIONS

MODEL | RAXIAL S4 (AC-RXS4)

DUCT SIZE | Ø4"

POWER USAGE | 15 W

CONTROLLER | Speed Controller

ENGINE | AC Motor

AIRFLOW | 106 CFM

NOISE | 28 dBA

SPEED | High, Medium, Low

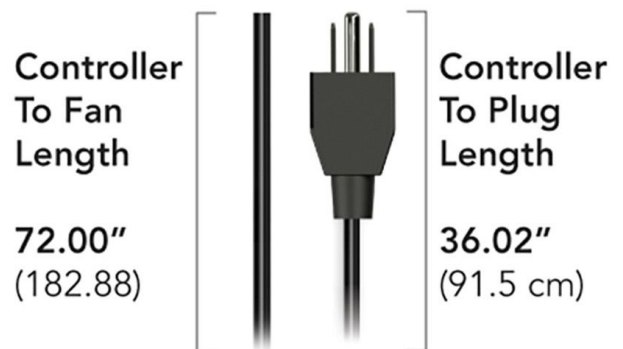
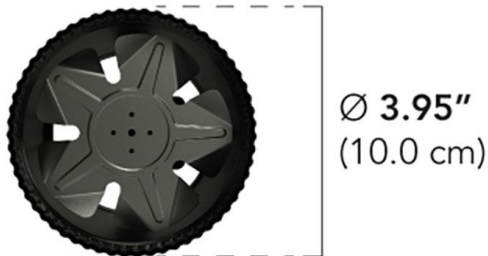
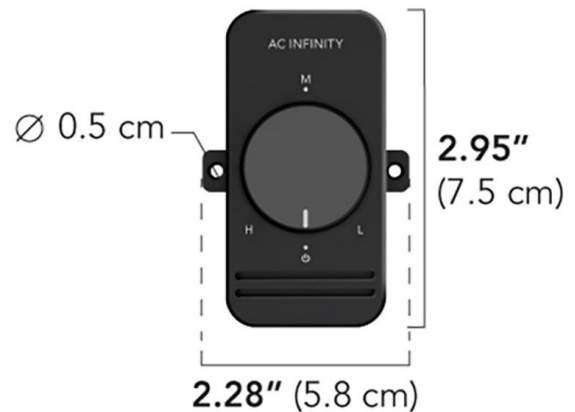

# SPECIFICATIONS

UIS™

MODEL | IONBEAM S11 (AC-NES11)  
POWER USAGE | 28 Watts  
PER SET | (4) 11" Light Bars

DIODES | Samsung LM301H EVO  
CONTROLS | Dimmer + Schedule  
IP RATING | IP65

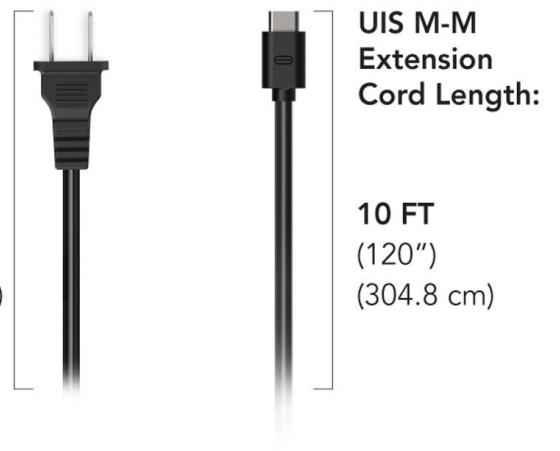
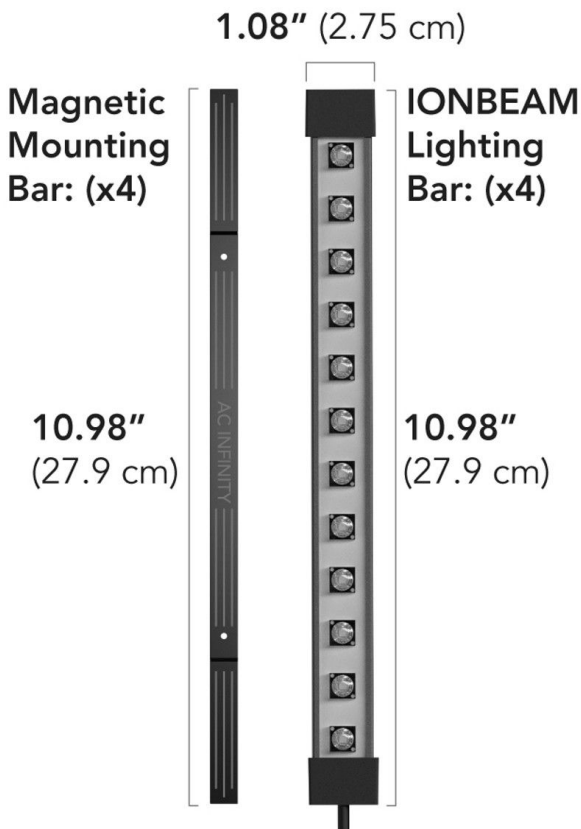
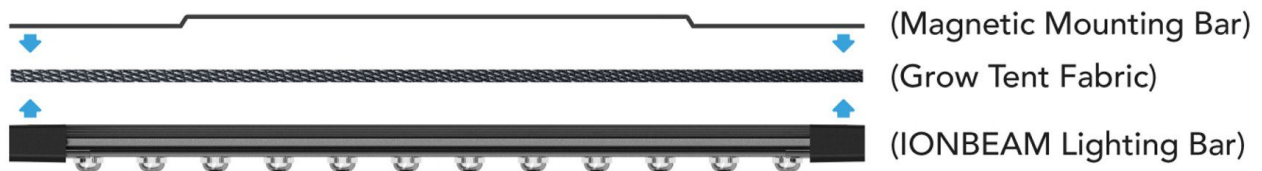

# SCHEDULE CONTROLLER

Programmable ON, OFF,  
and SCHEDULE modes

Ten Adjustable  
Intensity Levels



Power Outage  
Memory Retention

Programs Multiple  
Grow Lights

Detachable for  
Remote Mounting

# BEST IN CLASS LIGHTING

Features full spectrum Samsung **LM301H EVO** LEDs that deliver greater light intensity and efficiency when compared to all LM301H/B & Bridgelux 3030 diodes.

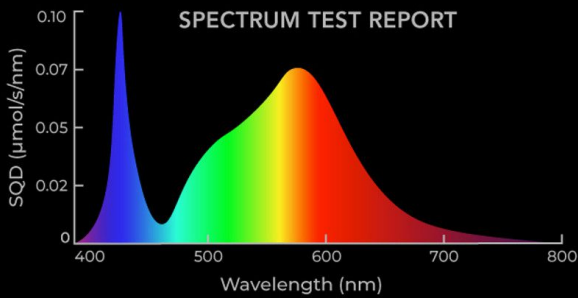

## PERFORMANCE COMPARISON

BRAND	MODEL	EFFICACY (PPF)
<b>SAMSUNG®</b>	<b>LM301H EVO</b>	<b>3.14 <math>\mu\text{mol/J}</math></b>
	LM301H	3.10 $\mu\text{mol/J}$
	LM301B	2.80 $\mu\text{mol/J}$
	LM301D	2.75 $\mu\text{mol/J}$
<b>OSRAM®</b>	S 3030	3.08 $\mu\text{mol/J}$
	E 2835	2.90 $\mu\text{mol/J}$
<b>CREE LED®</b>	3030	2.95 $\mu\text{mol/J}$
	2835	2.86 $\mu\text{mol/J}$
<b>Bridgelux®</b>	3030 BXEM	2.90 $\mu\text{mol/J}$

**3000K**

Promotes Plant Germination



**5000K**

Boosts Plant Flowering



**SAMSUNG**  
HORTICULTURE LED



Plant-centric  
Spectrum

Illuminated

**EVO**

